

4

3

2

1

THIS DRAWING IS UNPUBLISHED. RELEASED FOR PUBLICATION, 19 .
 © COPYRIGHT 19 BY AMP INCORPORATED. ALL RIGHTS RESERVED.

LOC	DIST	REVISIONS			
P	LTR	DESCRIPTION	DATE	DWN	APVD
G	14	J	ADD -1 PER 0G10-0070-99	16JUN99	JR MJS

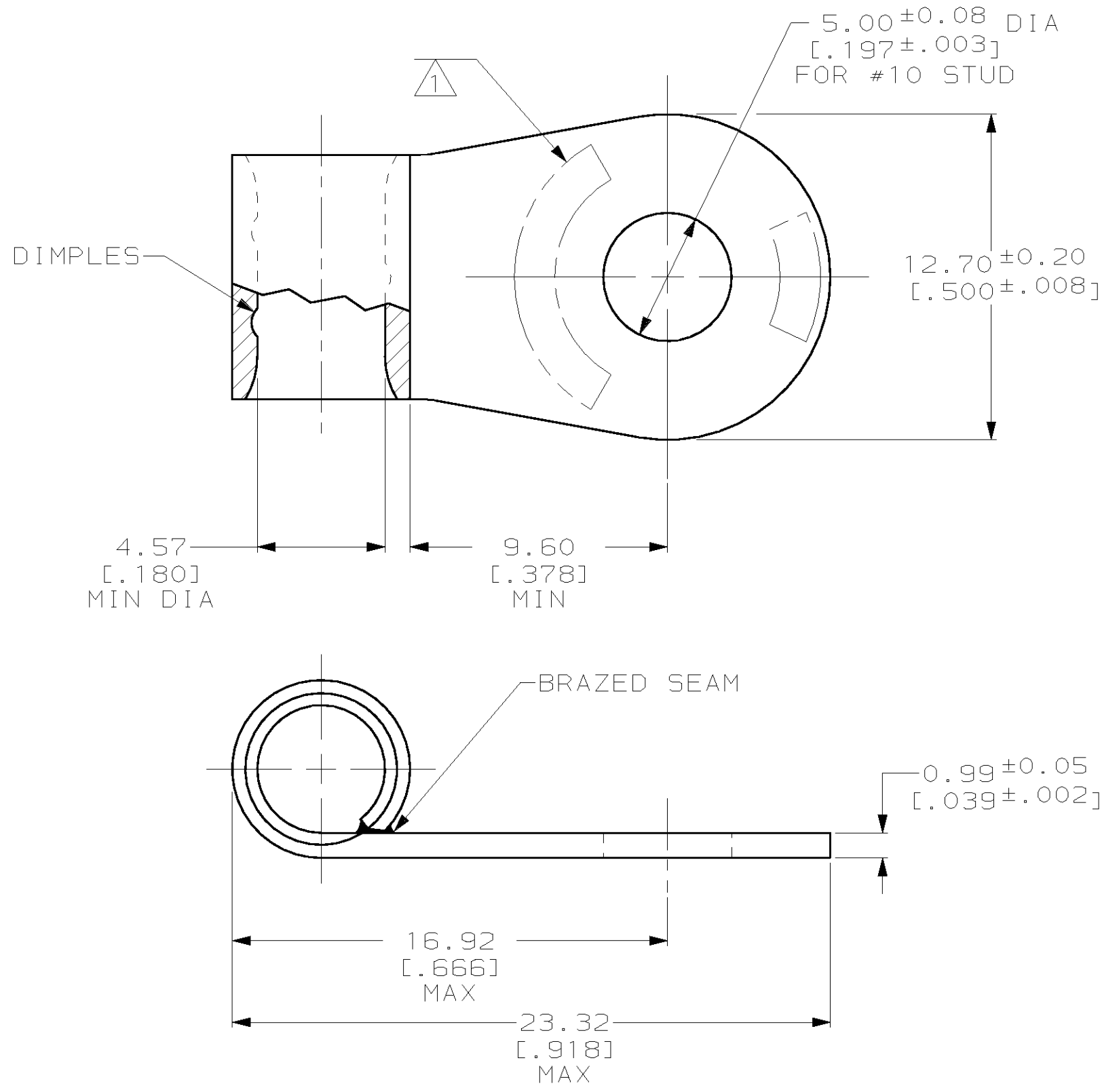

AMP WIRE RANGE	UL E13288 Listed
8 AWG SOLID OR STRANDED	8 AWG STRANDED
CS LR7189 Certified	
8 AWG SOLID OR STRANDED	

- ① STAMP AMP 8W* 14 APPROX AS SHOWN
- ② TIN PLATE 0.00254 [.000100] MIN THK PER ASTM B-545
- ③ GOLD PLATE 0.00127 [.000050] MIN THK PER ASTM B-488, TYPE 2, GRADE C OVER NICKEL PLATE 0.00076 [.000030] MIN THK PER QQ-N-290.

③	321441-1
②	321441
FINISH	AMP PART NUMBER

AMP INCORPORATED
CUSTOMER SERVICE SYSTEMS

FOR ADDITIONAL PRODUCT INFORMATION OR COPIES OF DRAWINGS AND TECHNICAL DOCUMENTS	PRODUCT INFORMATION CENTER 1-800-522-6752	RECOMMENDED OPERATING TEMPERATURE: 170°C MAX
FOR APPLICATION TOOLING INFORMATION	TOOLING ASSISTANCE CENTER 1-800-722-1111	VOLTAGE RATING: NOT APPLICABLE
FOR ORDER ENTRY	1-800-526-5142	WIRE CROSS SECTIONAL AREA RANGE: 6.64-10.5mm ² [13,100-20,800] CIR MILS SOLID OR STRANDED

THIS DRAWING IS A CONTROLLED DOCUMENT FOR AMP INCORPORATED. IT IS SUBJECT TO CHANGE AND THE CONTROLLING ENGINEERING ORGANIZATION SHOULD BE CONTACTED FOR THE LATEST REVISION.

DIMENSIONS: mm [INCHES]	TOLERANCES UNLESS OTHERWISE SPECIFIED:
	0 PLC ±-
	1 PLC ±-
	2 PLC ±0.20 [.008]
	3 PLC ±-
	4 PLC ±-
	ANGLES ±-
MATERIAL COPPER PER ASTM B-152 ANNEALED	FINISH SEE TABLE

DWN	DK SCHRUM	170CT97
CHK	MJ SPICER	200CT97
APVD	JL MECKLEY	200CT97
PRODUCT SPEC	-	-
APPLICATION SPEC	-	-
WEIGHT	-	-
CUSTOMER DRAWING		

AMP AMP Incorporated
 Harrisburg, PA 17105-3608

NAME: **TERMINAL, RING TONGUE, FLAG, SOLISTRAND™**

SIZE	CAGE CODE	DRAWING NO
A3	00779	C-321441
SCALE	SHEET	REV
5:1	1 OF 1	J